

Title: A theta-band EEG based index for early diagnosis of Alzheimer's disease

Running title: EEG based index to improve AD diagnosis

Esteve Gallego-Jutglà^a, Jordi Solé-Casals^{a*}, François-Benoît Vialatte^b, Justin Dauwels^c, Andrzej Cichocki^d

^a Data and Signal Processing Group, University of Vic – Central University of Catalonia, 08500 Vic, Catalonia, Spain

Telf: +34 938815519

Fax: +34 938814307

esteve.gallego@uvic.cat

jordi.sole@uvic.cat

^b ESPCI ParisTech, Laboratoire SIGMA, 75231 Paris Cedex 05, France

Telf: +33 (0)140794541

Fax: +33 (0)140794553

francois.vialatte@espci.fr

^c Nanyang Technological University, Singapore 639798

Telf: +65 67905410

jdauwels@ntu.edu.sg

^d BSI RIKEN ABSP Lab, Wako Saitama, 351-0198 Japan

Telf: +81 484679668

Fax: +81 484679686

cia@brain.riken.jp

* Corresponding author

Abstract

Despite recent advances, early diagnosis of Alzheimer's disease from electroencephalography remains a difficult task. In this paper, we offer an added measure through which such early diagnoses can potentially be improved. One feature that has been used for discriminative classification is changes in electroencephalography synchrony. So far, only the decrease of synchrony in the higher frequencies has been deeply analysed. In this paper, we investigate the increase of synchrony found in narrow frequency ranges within the θ band. This particular increase of synchrony is used with the well-known decrease of synchrony in the α band to enhance detectable differences between Alzheimer's patients and healthy subjects. We propose a new synchrony ratio that maximizes the differences between two populations. The ratio is tested using two different data sets, one of them containing Mild Cognitive Impairment patients and healthy subjects, and another one, containing Mild Alzheimer's Disease patients and healthy subjects. The results presented in this paper show that classification rate is improved, and the statistical difference between Alzheimer's patients and healthy subjects is increased using the proposed ratio.

Keywords

Alzheimer Disease; Mild Cognitive Impairment; Electroencephalography; Electroencephalography; Phase Synchronization; Data Interpretation, Statistical

Introduction

Alzheimer's disease (AD) is the most common type of dementia. It is characterized by cognitive deficits and behavioural disturbances. AD starts with difficulties to remember new information, and then individuals experience other difficulties as the disease progresses [1]. There is currently no cure for this disease, though several medications are believed to delay the symptoms [2]. An early diagnosis of AD is considered a key factor that could benefit patients in early stages of the disease, i.e., Mild Cognitive Impairment (MCI) or Mild AD.

In order to develop a system for an early diagnosis of AD, the potential of a recording technique known as electroencephalography (EEG) has been investigated. EEG consists in recording brain-related electrical potentials using different electrodes attached to the scalp [3]. EEG activity is commonly divided into specific frequency bands: 0.1-4 Hz (δ), 4-8 Hz (θ), 8-13 Hz (α), 13-30 Hz (β) and 30-100 Hz (γ) [3].

A large number of studies have analysed measurable changes that AD causes on EEG. A review of these studies can be found at [2,4,5]. Three major perturbations have been reported in EEG: (i) power increase of δ and θ rhythms and power decrease of posterior α and/or β rhythms in AD patients (also known as EEG slowing), (ii) EEG activity of AD patients seems to be more regular than the EEG recording of healthy subjects (which correspond to reduced complexity of the EEG signals for AD patients), and (iii) frequency-dependent abnormalities in EEG synchrony [2,4,6].

Frequency-dependent abnormalities in EEG synchrony in AD patients has been studied in detail [2,4]. Most of the studies have analysed synchrony changes in different frequency bands (δ , θ , α , β and γ) [7] by analysing synchrony differences between different brain regions [8], or by using multivariate measures [9]. These studies have mainly highlighted the decrease of synchrony in α and β bands for AD patients [10,11]. However, recent research [12] has revealed an increase of synchrony in narrow bands inside the θ band for Mild AD patients confirming the results presented in [13,14] for EEG signals or [15] for magnetoencephalography (MEG).

This paper aims to evaluate the discriminative power of this increase of synchrony in the θ band. We present a method enabling to use the increase of synchrony together with the well-known decrease of synchrony in high frequencies. We propose a ratio between synchrony measures in different frequency bands to improve the early diagnosis of AD. The ratio has been previously defined in [16]. However, the present study combines the ratio with the selection of specific frequency bands in a highly detailed

analysis of all possible combinations, which clearly enhances the discrimination between AD patients and healthy subjects.

Materials and Methods

The methods used in this paper to compute synchrony measures have already been defined in [17]. In our study, however, a new frequency approach is proposed, and a ratio is defined with synchrony values computed in a different frequency range. In this section, we first elaborate on the EEG data sets, next we discuss the applied synchrony measures and how we computed them.

EEG data sets

Two data sets are considered in this study. One data set contains EEG recordings of MCI patients and healthy subjects, and the other one contains EEG recordings of Mild AD patients and healthy subjects.

The MCI data set

Patients who only complained of memory impairment were recruited. They underwent thorough neuropsychological testing that revealed a quantified and objective evidence of memory impairment with no apparent loss in either general cognitive, behavioural, or functional status. The classification of very mild dementia impairment required a Mini-Mental Status Exam (MMSE) ≥ 24 and a Clinical Dementia Rating (CDR) scale score of 0.5 with memory performance less than one standard deviation below the normal reference (Wechsler Logical Memory Scale and Paired Associates Learning subtests, IV and VII, ≤ 9 , and/or ≤ 5 on the 30 min delayed recall of the Rey-Osterreith figure test). Fifty-three patients met these criteria. Each patient underwent Single-Photon Emission Computed Tomography (SPECT) at initial evaluation and was followed clinically for 12–18 months. Twenty-five of these fifty-three very mild AD patients developed probable or possible AD according to the criteria defined by the National Institute of Neurological and Communicative Disorders and Stroke, and the Alzheimer's disease and Related Disorders Association (NINDS-ADRDA). These subjects formed our group of patients of the MCI data set (age: 71.9 ± 10.2 years old), while 56 age-matched healthy subjects constituted the control group (age: 71.7 ± 8.3 years old). EEG recordings were conducted at the MCI stage. The control group consisted of healthy subjects who had no memory or other cognitive impairments. The scores of the MMSE were 28.5 ± 1.6 for the control group and 26 ± 1.8 for the MCI patients.

The EEG time series were recorded using 21 electrodes, positioned according to the 10-20 international system, with the reference electrode on the right earlobe. EEG was recorded with Biotop 6R12 (NEC Sanei, Tokyo, Japan) at a sampling rate of 200Hz, with analog bandpass filtering in the frequency range

0.5-250 Hz and online digital bandpass filtering between 4 and 30 Hz, using a third-order Butterworth filter (forward and reverse filtering).

The Mild AD data set

The Mild AD data set consists of 24 healthy control subjects (age: 69.4 ± 11.5 years old) and 17 patients with mild AD (age: 77.6 ± 10.0 years old). The patient group underwent a full battery of cognitive tests (MMSE, Rey Auditory Verbal Learning Test, Benton Visual Retention Test, and memory recall tests). The results from the psychometric tests were scored and interpreted by a psychologist, and all clinical and psychometric findings were discussed at a multidisciplinary team meeting. All age matched controls were healthy volunteers and had normal EEGs (confirmed by a Consultant Clinical Neurophysiologist). The EEG time series were recorded using 19 electrodes positioned according to the Maudsley system, similar to the 10-20 international system, at a sampling frequency of 128 Hz. The EEGs were band-pass filtered with a digital third-order Butterworth filter (forward and reverse filtering) between 4 and 30 Hz.

Recording Conditions Common to Both Data Sets

In both data sets, all recording sessions were conducted with the subjects in a wakeful but resting state with eyes closed. The length of the EEG recording was about 5 minutes for each subject. Only those subjects were retained in the analysis whose EEG recordings contained at least 20s of artefact-free data. As a result of this approach, the number of subjects of the MCI data set was further reduced to 22 MCI patients and 38 control subjects; in the Mild AD data set no reduction was made. For the subjects eventually included in each data set, statistical differences between the ages of the patients were checked. For none of these two data sets the age difference between patients and control subjects is significant (t-test $p \gg 0.05$).

From each subject in both data sets, one artefact-free EEG segment of 20s was analysed. For the MCI data set, a researcher pre-processed the data by visual inspection and selected portions of 20 sec with no visible artefacts. No further pre-processing on this data was applied. For the Mild AD data set, artefact rejection method described in [18] was applied on visually clean selected portions of 20 sec.

Procedures

Synchrony measures

In order to study the increase of synchrony in the θ band, a set of synchrony measures was used: Coherence, Granger Causality (including Granger coherence, Partial coherence (PC), Directed transfer function (DTF), Full frequency directed transfer function (ffDTF), Partial directed coherence (PDC),

Direct directed transfer function (dDTF), Omega Complexity, and Phase Synchrony. These synchrony measures have been previously reviewed in [17].

Bandpass filtering and computation of EEG Measures

Signals were bandpass filtered using third order Butterworth filters. Butterworth filters were selected since they can easily be implemented, and they offer a magnitude response that is maximally flat in the pass band.

Two different sets of frequency ranges were defined for this study. All the possible frequency ranges inside the θ band and the α band were used, defining two sets of frequency ranges. For the first set of frequency ranges ($\theta(f_1, f_2)$), the starting frequency f_1 varied from 4 to 7 Hz, and the width W varied from 1 to 4 (e.g. 4-5 Hz, 4-6 Hz, 4-7 Hz, 4-8 Hz, ... 7-8 Hz). The maximum frequency of analysis ($f_2 = f_1 + W$) was limited to 8 Hz. A total of 10 frequency ranges were used for the study.

For the second set of frequency ranges, the α band was analysed ($\alpha(f_3, f_4)$). In this case, f_3 varied from 8 to 12 Hz, and W varied from 1 to 5 (e.g. 8-9 Hz, 8-10 Hz, 8-11 Hz, 8-12 Hz, ... 12-13 Hz). The maximum frequency of analysis ($f_4 = f_3 + W$) was limited to 13 Hz. A total of 15 frequency ranges were used for this study.

The computation of synchrony measures was performed as defined in [17]. For bivariate measures, electrodes were aggregated into five different regions, with each region corresponding to a specific brain area, i.e. frontal, parietal, occipital and left and right temporal. To compute the synchrony between two regions, one first computes the synchrony between each EEG signal from one region and each signal from the other. The next step is evaluating synchrony measures by computing the average synchrony values of these signal pairs. Once the synchrony between each region pair is computed, the average of synchrony between regions (10 pairs) is calculated to obtain a global synchrony value for each subject.

A different approach was used to compute EEG synchrony for multivariate measures. The Omega complexity was applied to all EEG signals of the data set. However, for the Granger measures this would have required estimating a 21-dimensional Multivariate Autoregressive (MVAR) model. In order to avoid this high dimensional estimation, time averaging between electrodes of the same region was computed, leading to averaged EEG time series for each of the five above defined regions. The Granger measures were then applied to these five averaged EEG signals [17]. Finally, the Granger values between the regions were averaged (10 pairs) to obtain a global synchrony measure.

Statistical analysis

To evaluate the difference between populations, the statistical significance of the differences between synchrony values was studied using the Mann-Whitney test. Differences between MCI patients and control subjects as well as between Mild AD patients and control subjects were studied.

The Mann-Whitney test is a non-parametric test that allows us to investigate statistical differences between two populations without assumptions of Gaussianity (most of the measured distributions are non-Gaussian). Low p-values indicate significant differences between the medians of the two populations.

Synchrony ratio and classification

To evaluate the difference between populations representing an increase of synchrony in the θ band, we defined the following ratio by dividing a synchrony value in the θ band ($sync_{\theta}(f_1, f_2)$) by a synchrony value in the α band ($sync_{\alpha}(f_3, f_4)$):

$$r = \frac{sync_{\theta}(f_1, f_2)}{sync_{\alpha}(f_3, f_4)} \quad (1)$$

Ratio (1) was computed for each of the measures. This ratio aims to maximize the distance between populations. As presented in [12], an increase of synchrony was discovered for Mild AD subjects in the θ band for narrow bands. Therefore the synchrony in the θ band is placed in the numerator of the ratio. On the basis of existing literature [2,4], we also know that there is a decrease of synchrony for AD patients in the α band. Therefore the synchrony in the α band is placed in the denominator increasing the value of r for AD patients.

The values $sync_{\theta}(f_1, f_2)$ and $sync_{\alpha}(f_3, f_4)$ refer to the synchrony values computed in the θ band and the α band, respectively. Frequency ranges $\theta(f_1, f_2)$ and $\alpha(f_3, f_4)$ are selected for each measure in order to maximize the difference between AD and healthy subjects. Given this aim, the frequency range to be used in $\theta(f_1, f_2)$ is the one that presents the highest synchrony mean value for AD patients in comparison with healthy subjects. Therefore $sync_{\theta}(f_1, f_2)$ is the synchrony value computed in that frequency range. The same procedure is applied to define $\alpha(f_3, f_4)$. However, as we are looking for a decrease of synchrony in AD patients in the α band, the frequency range used in $\alpha(f_3, f_4)$ is the one that presents the minimum mean value for AD patients. By selecting the frequency range $\theta(f_1, f_2)$ with higher mean value for AD patients and the frequency range $\alpha(f_3, f_4)$ with lower mean value for AD patients we are maximizing the differences between AD and healthy subjects. Later on, this will make it easier to distinguish between

these two populations. This procedure designed to select $\theta(f_1, f_2)$ and $\alpha(f_3, f_4)$ was repeated for each of the measures we used.

Classification Rate (CR) was computed using Linear Discriminant Analysis (LDA). LDA was used to classify computed synchrony measures obtained from the EEG data of AD patients and control subjects. As the number of subjects in the database is small, the Leave-One-Out (LOO) procedure was used. In this LOO cross-validation scheme of N observations, $N-1$ are used for training while the last one is used for evaluation. This process is repeated N times, leaving one different observation for evaluation each time. The mean success classification value in percentage (%) is obtained as a final result.

Results

The presented ratio was used to improve the early diagnosis of patients with AD. Table 1 presents the values obtained using the ratio. In this table, for each data set, we show the selected frequency range inside the θ band and the α band, $\theta(f_1, f_2)$ and $\alpha(f_3, f_4)$, respectively. The CR and p-values are displayed. Frequency ranges that do not present any increase (θ band) or decrease (α band) of synchrony for AD patients are highlighted in blue. In these highlighted values, the standard θ and α bands were used instead of a specific frequency range.

As it can be seen from the results in Table 1, using the ratio rather than only the synchrony value improves CR for the MCI data set for several measures: Coherence, PC, DTF, ffDTF and dDTF. The same measures give a lower p-value in comparison with that obtained individually. For the MCI dataset the best CR is 83.33% (sensitivity 81.82% and specificity 84.21%) obtained by dDTF. The second and the third best results, obtained by DTF and ffDTF, are 75.00% (sensitivity 68.18% and specificity 78.95%). The results presented for the Mild AD data set show that the CR obtained with the ratio in all measures has values equal to or higher than the value obtained with the synchrony measures only. The p-values computed for the ratio were also lower than those obtained using the synchrony measure only. The CR is also improved for almost all measures in comparison with obtained results using individual features. The best CR is 87.80% (sensitivity 82.35% and specificity 91.67%) obtained by DTF. The second and the third best results obtained are 82.93% obtained by PC (sensitivity 76.47% and specificity 87.50%) and dDTF (sensitivity 58.82% and specificity 100%).

Fig. 1 and Fig. 2 contain the box plots of the synchrony values and the ratio for all measures. Both figures show that for almost all the measures, AD patients have higher synchrony values in the θ band and lower synchrony values in the α band. In Fig. 1 (which corresponds to the MCI data set) measures that present a

clear difference are those that achieved the best classifications results (DTF, ffDTF and dDTF). In Fig. 2, our results for the Mild AD data set are presented. In this figure, measures that present a clear difference are PC, DTF and dDTF, again those that obtained the best CR. In both cases the ratio increases the distance between two distributions, which makes it easier to classify subjects into one of the groups, as the results of the CR have shown.

Discussion

The results we have presented show that the ratio improves classification of the individuals as either AD patients or healthy subjects. The p-values obtained are smaller for the ratio than for the synchrony measures alone. The results obtained for the Mild AD data set present higher CR than the results obtained for the MCI data set. The box plots shown in Fig. 1 and in Fig. 2 demonstrate that the ratio increases the difference between AD patients and healthy subjects. However, results obtained with the Mild AD data set present a higher difference than the ones obtained with the MCI data set.

Interestingly, most of the results were obtained in narrow band frequency ranges, with a width of one or two hertz. The frequency range of 4-5 Hz appears in both data sets as one where the synchrony is higher for AD patients than for healthy subjects. On the other hand, the frequency range of 12-13 Hz appears in the α band as that where the synchrony is lower for AD patients.

Our results show that for the MCI data set we achieve a CR of 83.33% and for Mild AD data set we achieve a CR of 87.8%. Previous studies using these data sets and synchrony measures achieved comparable results. In [17,19] the same results were achieved using the MCI data set, but in this case using two measures as input features to a LDA classifier. When these studies used only one measure as a single feature, the best CR decreased to 70.0%. For the Mild AD data set a CR of 85.0% was achieved using two measures and LDA, but using only one measure the CR decreased to 82.9% in [19]. The two obtained values in [19] are lower than the ones obtained in this study.

Different results were obtained in [20] where a combination of Relative Power (RP) and other measures were used. The best result in [20] for MCI data set was 78.33% using Stochastic Event Synchrony and the RP in the θ band as input features into a LDA classifier. Therefore, for the MCI data set, the ratio and optimization of the frequency ranges clearly improves the CR and simplify the classification system. However, for the Mild AD data set, using RP in the θ band and ffDTF as features, the best CR obtained was 95.12%. This result improves our best CR for this data set. Nevertheless, it is important to note that: (i) input space is two-dimensional (a vector of two features as input for the classifier), whereas we have

only one-dimensional space and (ii) features used to obtain the best CR were different for both data sets, whereas we use the ratio in both data sets. Keeping in mind that the objective is to deal with the early diagnosis of AD, our proposed ratio r yields good classification performance on both EEG data sets, which is interesting for medical applications.

On the other hand, earlier studies were mainly focused on the decrease of synchrony for AD patients in higher frequencies [4,17,21]; only a few studies have presented an increase of synchrony in the θ band. In our study, such increase of synchrony in the θ band is confirmed for Mild AD patients, and an increase of synchrony in narrow bands is also found in MCI subjects. Other earlier studies [13,22–25] also presented an increase of synchrony in the θ band, usually in a specific region like the posterior cingulate gyrus area, or the area covered by the electrodes P3-P4, C3-C4, F3-F4 and FP1-FP2. Locatelli et. al. [14] found an increase of synchrony in the θ band only for a limited number of subjects who displayed severe cognitive problems. Other studies [11] reported an increase of global synchrony in the θ band using a multivariate measure. Some of the above studies highlight the decrease of synchrony in the α band, instead of the increase in θ band. Our results show an increase on the global synchrony value in the θ band. Mild AD patients present a higher increase of synchrony in the θ band than MCI patients. This may be related to the fact that Mild AD is a stage in which the cognitive deficits are higher than in MCI [23].

Comparing results from different studies remains a difficult task. The most important issue is the high variability among the different methods used in the studies. Few studies consider multiple synchrony measures. Usually only one synchrony measure is considered in each paper, which is often different in each study. Besides, experimental conditions between studies may be different, e.g., different recording conditions, electrode placements, and/or patient inclusion criteria. This last condition may be a key factor to explain the variability of results found in the literature. Finally, it should be noted that our two data sets are fairly small. A larger database is required in order to generalize our results.

In future work we will further explore several aspects. First, we will analyse whether a better CR could be achieved by combining the proposed ratio with different synchrony measures. Second, we will investigate changes in the inter-region synchrony instead of global synchrony; this will allow us to identify which regions exhibit the strongest perturbations in synchrony, and therefore to obtain more insight on how to discriminate AD patients from healthy subjects. Third, we plan to study how the spatial averaging approach affects the synchrony, due to the fact that it may affect the values of inter-region and global synchrony. Finally we plan to investigate if the ratio can be useful in the early diagnose of other

neurodegenerative diseases, or if it can help to distinguish between different types of neurodegenerative disease, for example between AD and Vascular Dementia.

Acknowledgements

Esteve Gallego-Jutglà thanks the University of Vic–Central University of Catalonia (UVic-UCC) for partially supporting this project under a PhD grant (“Amb el suport de l'ajut predoctoral de la Universitat de Vic – Universitat Central de Catalunya”). Jordi Solé-Casals and Esteve Gallego-Jutglà acknowledge support from the University of Vic–Central University of Catalonia (grant R0947). The authors would like to acknowledge anonymous reviewers for their detailed and helpful comments to the manuscript and to V. Zaiats for his help on reviewing the final version of the manuscript.

References

- [1] Alzheimer's Association (2014) 2014 Alzheimer's disease facts and figures. *Alzheimer's Dement.* **10**, e47–e92.
- [2] Dauwels J, Vialatte F, Cichocki A (2010) Diagnosis of Alzheimers Disease from EEG Signals: Where Are We Standing? *Curr. Alzheimer Res.* **7**, 487–505.
- [3] Nunez P, Srinivasan R (2006) *Electric fields of the brain: the neurophysics of EEG*, Oxford university press.
- [4] Jeong J (2004) EEG dynamics in patients with Alzheimer's disease. *Clin. Neurophysiol.* **115**, 1490–1505.
- [5] Vecchio F, Babiloni C, Lizio R, De Vico Fallani F, Blinowska K, Verrienti G, Frisoni G, Rossini PM (2013) Resting state cortical EEG rhythms in Alzheimer's disease: Toward EEG markers for clinical applications: A review. *Suppl. Clin. Neurophysiol.* **62**, 223–236.
- [6] Babiloni C, Vecchio F, Lizio R, Ferri R, Rodriguez G, Marzano N, Frisoni GB, Rossini PM (2011) Resting state cortical rhythms in mild cognitive impairment and Alzheimer's disease: Electroencephalographic evidence. *Adv. Alzheimer's Dis.* **2**, 391–404.
- [7] Stam CJ, Montez T, Jones BF, Rombouts SARB, van der Made Y, Pijnenburg YAL, Scheltens P (2005) Disturbed fluctuations of resting state EEG synchronization in Alzheimer's disease. *Clin. Neurophysiol.* **116**, 708–15.
- [8] Tóth B, File B, Boha R, Kardos Z, Hidasi Z, Gaál ZA, Csibri E, Salacz P, Stam CJ, Molnár M (2014) EEG network connectivity changes in mild cognitive impairment - Preliminary results. *Int. J. Psychophysiol.* **92**, 1–7.
- [9] Yi R, Zhan X-R, Tang J, Zhang L-M, Liu X-M, Dong Q (2014) EEG Synchronization Evaluation: A New Diagnostic Tool for Predicting the Progression of Alzheimer's disease. *Clin. EEG Neurosci.* 1550059413502779.
- [10] Hsiao F-J, Wang Y-J, Yan S-H, Chen W-T, Lin Y-Y (2013) Altered oscillation and synchronization of default-mode network activity in mild Alzheimer's disease compared to mild cognitive impairment: an electrophysiological study. *PLoS One* **8**, e68792.
- [11] Koenig T, Prichep L, Dierks T, Hubl D, Wahlund LO, John ER, Jelic V (2005) Decreased EEG synchronization in Alzheimer's disease and mild cognitive impairment. *Neurobiol. Aging* **26**, 165–171.
- [12] Gallego-Jutglà E, Elgendi M, Vialatte F, Solé-Casals J, Cichocki A, Latchoumane C, Jeong J, Dauwels J (2012) Diagnosis of Alzheimer's disease from EEG by means of synchrony measures in optimized frequency bands. In *Engineering in Medicine and Biology Society (EMBC), 2012 Annual International Conference of the IEEE*, pp. 4266–4270.
- [13] Adler G, Brassens S, Jajcevic A (2003) EEG coherence in Alzheimer's dementia. *J. Neural Transm.* **110**, 1051–8.
- [14] Locatelli T, Cursi M, Liberati D, Franceschi M, Comi G (1998) EEG coherence in Alzheimer's disease. *Electroencephalogr. Clin. Neurophysiol.* **106**, 229–237.
- [15] Stam CJ, Jones BF, Manshanden I, van Cappellen van Walsum AM, Montez T, Verbunt JPA, de Munck JC, van Dijk BW, Berendse HW, Scheltens P (2006) Magnetoencephalographic evaluation of resting-state functional connectivity in Alzheimer's disease. *Neuroimage* **32**, 1335–44.

- [16] Gallego-Jutglà E, Solé-Casals J (2013) Improving early diagnosis of Alzheimer's disease using synchrony measures. In *Frontiers in Artificial Intelligence and Applications*, pp. 167–170.
- [17] Dauwels J, Vialatte FB, Musha T, Cichocki A (2010) A comparative study of synchrony measures for the early diagnosis of Alzheimer's disease based on EEG. *Neuroimage* **49**, 668–693.
- [18] Vialatte F-B, Solé-Casals J, Maurice M, Latchoumane C, Hudson N, Wimalaratna S, Jeong J, Cichocki A (2009) Improving the Quality of EEG Data in Patients with Alzheimer's Disease Using ICA. *Adv. Neuro-Information Process.* 979–986.
- [19] Dauwels J, Vialatte F, Latchoumane C, Jeong J, Cichocki A (2009) EEG synchrony analysis for early diagnosis of Alzheimer's disease: a study with several synchrony measures and EEG data sets. *Conf. Proc. IEEE Eng. Med. Biol. Soc.* **2009**, 2224–2227.
- [20] Dauwels J, Srinivasan K, Ramasubba Reddy M, Musha T, Vialatte F-B, Latchoumane C, Jeong J, Cichocki A (2011) Slowing and Loss of Complexity in Alzheimer's EEG: Two Sides of the Same Coin? *Int. J. Alzheimers. Dis.* **2011**, 539621.
- [21] Van der Hiele K, Vein AA, Reijntjes R, Westendorp RGJ, Bollen E, van Buchem MA, van Dijk JG, Middelkoop HAM (2007) EEG correlates in the spectrum of cognitive decline. *Clin. Neurophysiol.* **118**, 1931–1939.
- [22] Babiloni C, Ferri R, Binetti G, Cassarino A, Forno GD, Ercolani M, Ferreri F, Frisoni GB, Lanuzza B, Miniussi C (2006) Fronto-parietal coupling of brain rhythms in mild cognitive impairment: a multicentric EEG study. *Brain Res. Bull.* **69**, 63–73.
- [23] Knyazeva MG, Jalili M, Brioschi A, Bourquin I, Fornari E, Hasler M, Meuli R, Maeder P, Ghika J (2010) Topography of EEG multivariate phase synchronization in early Alzheimer's disease. *Neurobiol. Aging* **31**, 1132–1144.
- [24] Knyazeva MG, Carmeli C, Khadivi A, Ghika J, Meuli R, Frackowiak RS (2013) Evolution of source EEG synchronization in early Alzheimer's disease. *Neurobiol. Aging* **34**, 694–705.
- [25] Kramer MA, Chang F-L, Maurice EC, Hudson D, Andrew JS (2007) Synchronization measures of the scalp electroencephalogram can discriminate healthy from Alzheimer's subjects. *Int. J. Neural Syst.* **17**, 61–69.

Table 1 - Computed values of CR and p-values for several different scenarios: The frequency range that presented the highest mean synchrony value for each data set in the θ band, the frequency range that presented the lowest mean synchrony value for each data set in the α band, and the ratio computed between those frequency ranges. In bold the three best results obtained for each data set using the ratio.

MCI Data set								
Measure	Selected freq. range $\theta(f_1, f_2)$	CR $\theta(f_1, f_2)$ (%)	p-value $\theta(f_1, f_2)$	Selected freq. range $\alpha(f_3, f_4)$	CR $\alpha(f_3, f_4)$ (%)	p-value $\alpha(f_3, f_4)$	CR Ratio (%)	p-value $\theta(f_1, f_2)$ $/\alpha(f_3, f_4)$
Coherence	5 - 6	61.67	0.2661	8 - 9	60.00	0.0470	66.67	0.0111
Granger Coherence	4 - 8	61.67	0.0089	8 - 11	63.33	0.0132	53.33	0.4295
PC	6 - 7	61.67	0.0324	12 - 13	56.67	0.2406	70.00	0.0006
DTF	4 - 5	53.33	0.6289	12 - 13	60.00	0.0901	75.00	0.0022
ffDTF	4 - 5	53.33	0.6289	12 - 13	60.00	0.0872	75.00	0.0021
PDC	4 - 5	58.33	0.0256	8 - 13	56.67	0.6181	58.33	0.0300
dDTF	6 - 7	70.00	0.0144	12 - 13	61.67	0.0078	83.33	8.81×10^{-7}
Omega Complexity	5 - 6	50.00	0.3534	8 - 10	68.33	0.0138	58.33	0.0277
Phase synchrony	4 - 8	60.00	0.1347	8 - 10	70.00	0.0093	55.00	0.1746
Mild AD Data set								
Measure	Selected freq. range $\theta(f_1, f_2)$	CR $\theta(f_1, f_2)$ (%)	p-value $\theta(f_1, f_2)$	Selected freq. range $\alpha(f_3, f_4)$	CR $\alpha(f_3, f_4)$ (%)	p-value $\alpha(f_3, f_4)$	CR Ratio (%)	p-value $\theta(f_1, f_2)$ $/\alpha(f_3, f_4)$
Coherence	5 - 6	68.29	0.0179	10 - 11	68.29	0.0002	80.49	4.86×10^{-5}
Granger Coherence	4 - 5	75.61	0.0003	10 - 11	58.54	0.2286	75.61	0.0001
PC	4 - 5	63.41	0.0091	9 - 10	56.10	0.0550	82.93	0.0001
DTF	6 - 7	87.80	3.41×10^{-6}	12 - 13	63.41	0.1094	87.80	4.41×10^{-6}
ffDTF	4 - 5	73.17	1.71×10^{-5}	12 - 13	73.17	0.0155	80.49	9.31×10^{-6}
PDC	4 - 5	75.61	3.88×10^{-6}	12 - 13	73.17	0.0072	78.05	1.20×10^{-6}
dDTF	4 - 5	73.17	0.0001	12 - 13	65.85	0.0155	82.93	1.78×10^{-6}
Omega Complexity	4 - 6	56.10	0.2088	8 - 13	63.41	0.0206	78.05	0.0005
Phase synchrony	5 - 6	65.85	0.0457	8 - 11	70.73	0.0002	78.05	2.74×10^{-5}

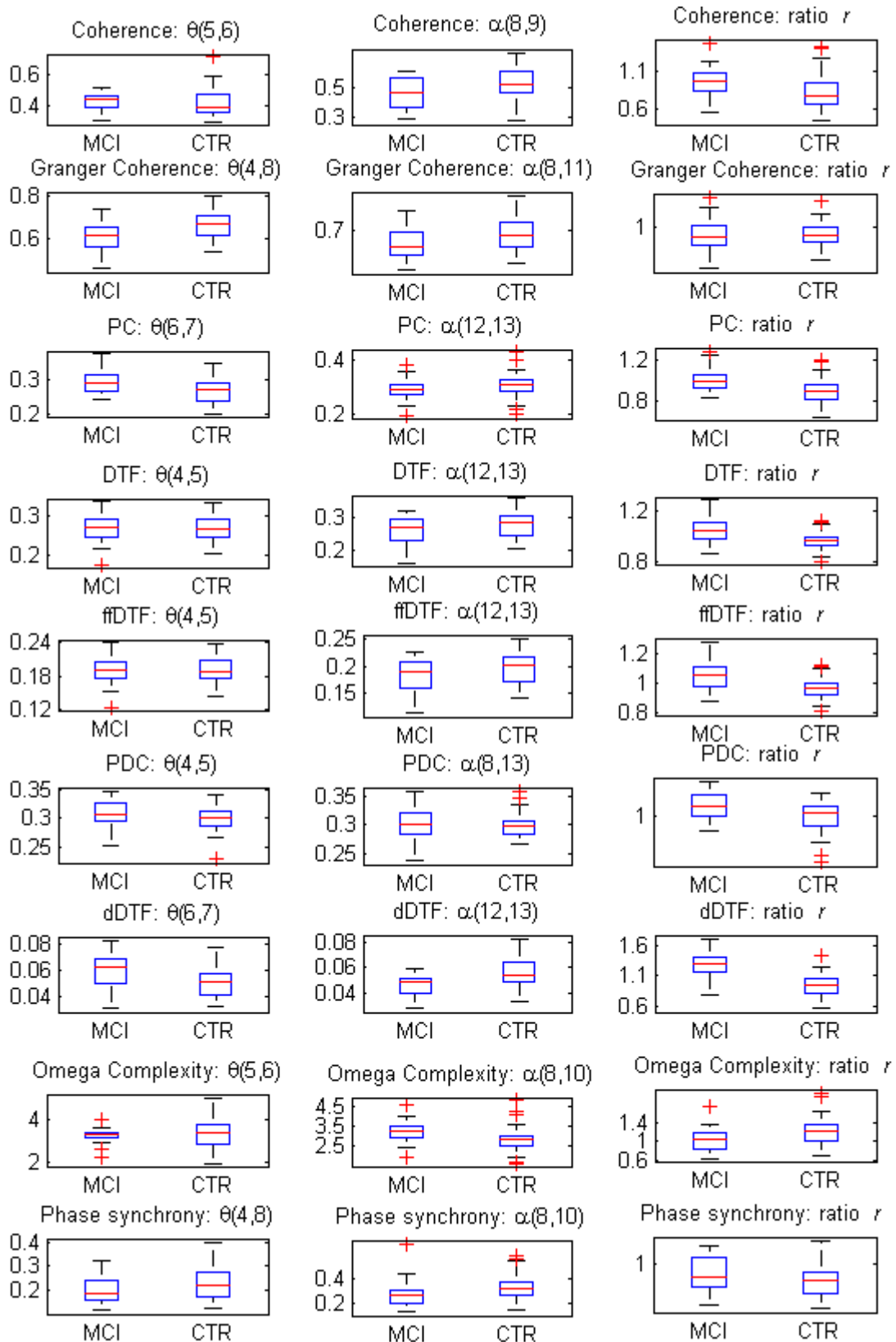

Fig. 1- Box plots showing the results obtained with the MCI data set. Third column shows the results obtained for the ratio. We can observe that box plots are more separated using the ratio than using only θ or α bands (specific frequency range in Hz on the top of each box plot).

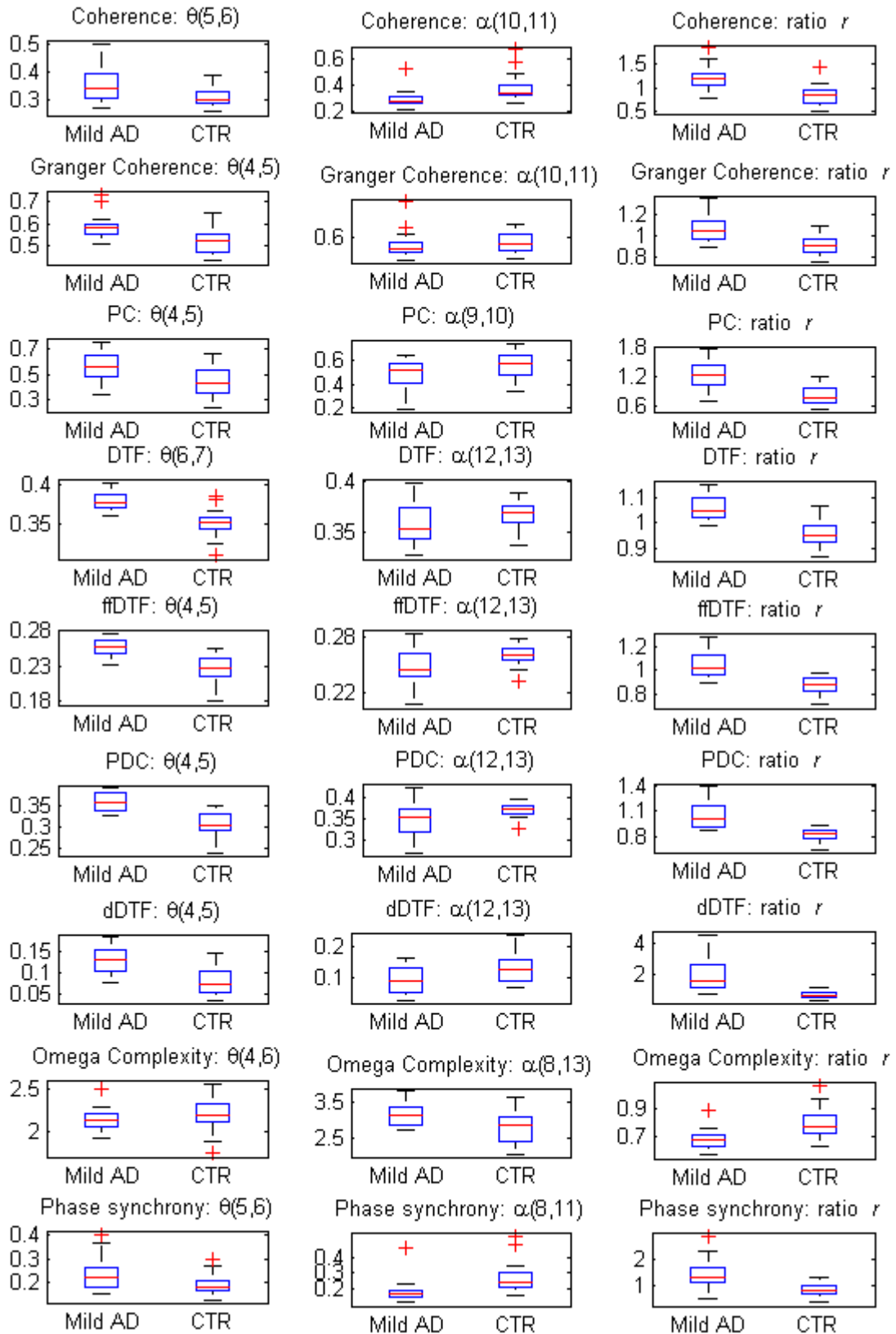

Fig. 2 - Box plots showing the results obtained with the Mild AD data set. Third column shows the results obtained for the ratio. We can observe that box plots are more separated using the ratio than using only θ or α bands (specific frequency range in Hz on the top of each box plot).